

角フリューム

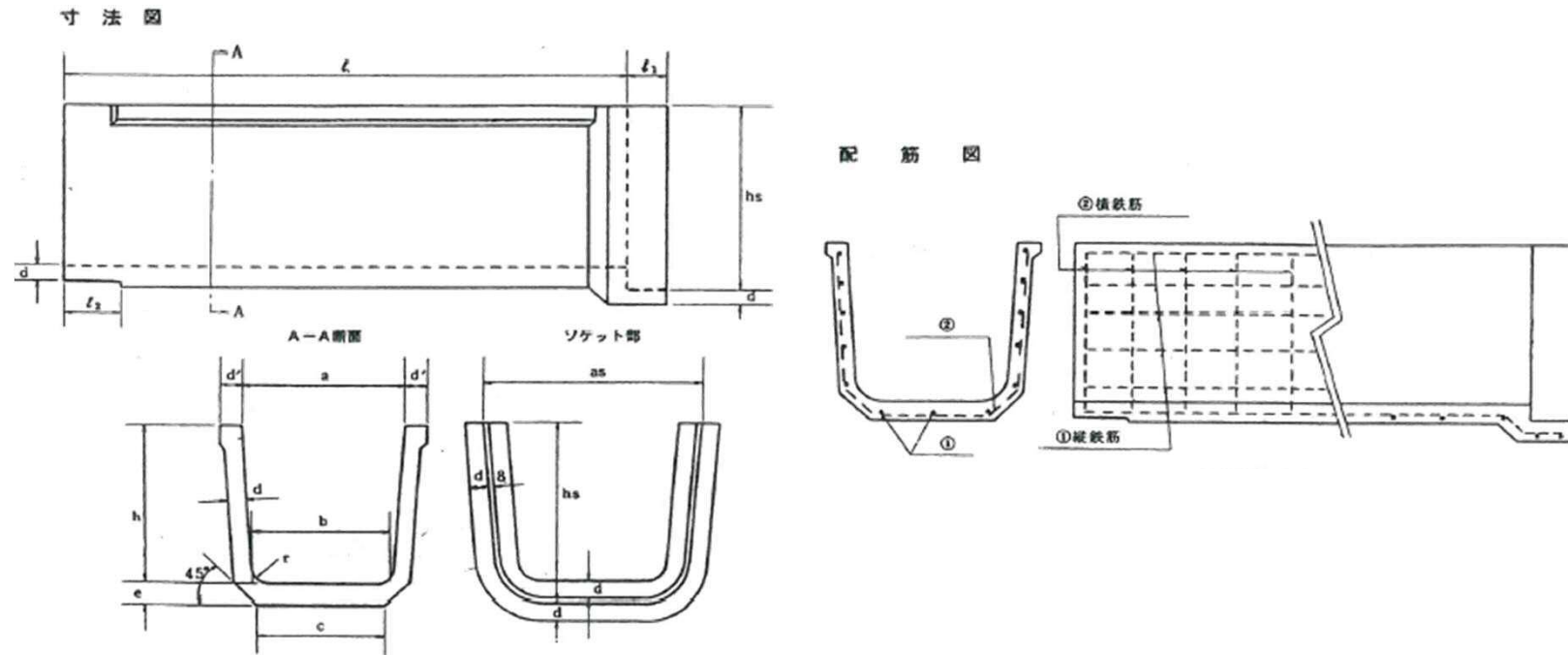

寸法表

呼称	寸法表(mm)												
	a	b	c	d	d'	e	h	hs	as	r	l	l1	l2
150	150	130	120	20	30	23	150	178	206	30	1995	60	80
200	200	173	143	25		29	200	233	266				
250	250	217	187		35		300	338	376				
300	300	260	234	30	40	350	388	426	50	80		100	
350	350	303	277			400	448	496					
400	400	347	329	40	50	46	450	498	546	70			
450	450	390	350			500	558	616					
500	500	433	403	50	60	57	500	558	616				

配筋表

①縦鉄筋		②横鉄筋	
径(mm)	本数	径(mm)	本数
2.6	8	2.6	12
	11		22
2.9	11	2.9	24
	13		26
3.2	15	4.0	24
	15		26
4.0	15	5.0	22
5.0	16		24

寸法許容差

呼称	許容差(mm)			
	a・b	h	d・d'・e	l
150~300	±3	±2	±2	±5
350~500	±5	±3	+3 -2	±5