

G1%)

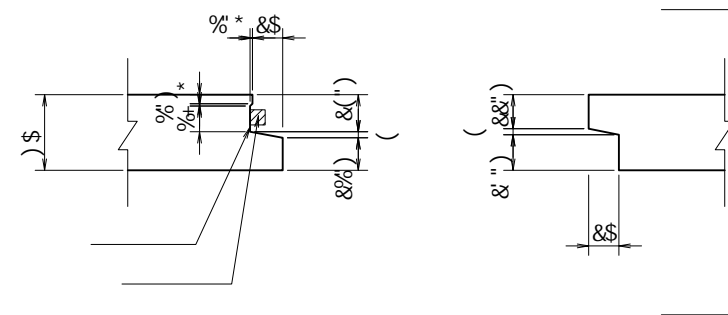
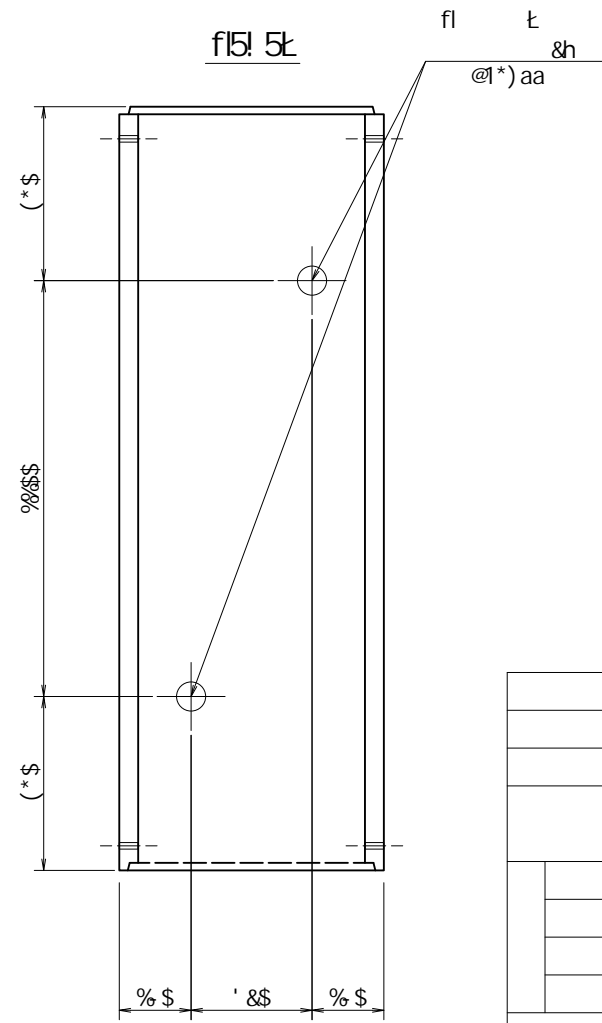
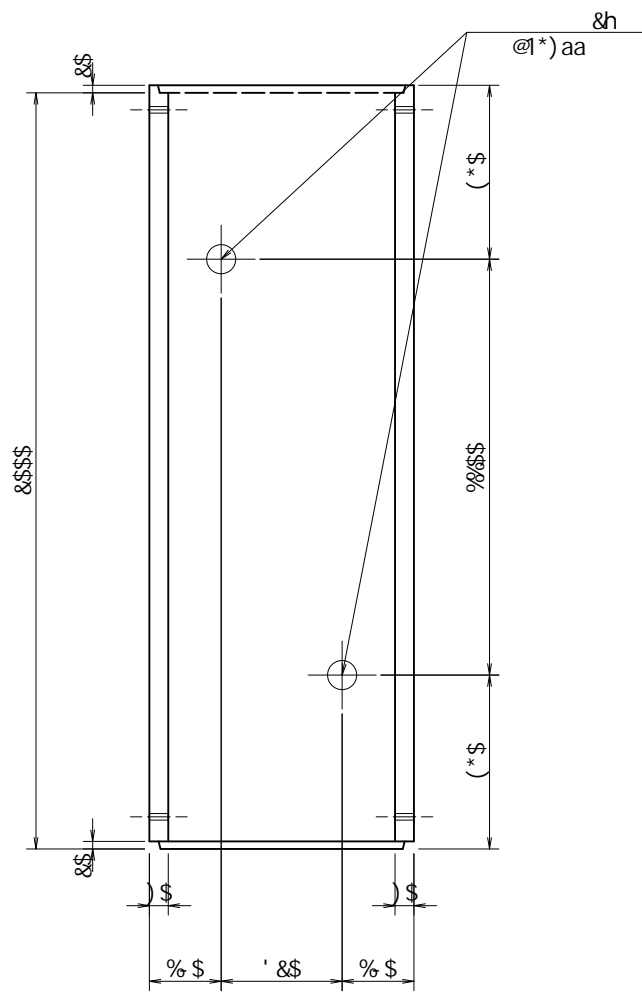

	\$" \$\$\$a	(" (\$\$a
	—	H &)
	B#a'	' &(")
	B#a'	'%" "\$
	B#aa&	' ')" "\$
	B#aa&	'%&" "\$
	B#aa&	' '\$)" "\$
FIG&-)	t	B#aa&
		' '\$)"

		* \$\$! &\$\$\$	
	<&&" %%" &(&		% &\$
			<! %\$\$*% %)

VERTEX ベルテクス株式会社

&\$\$/#/8/#/9)

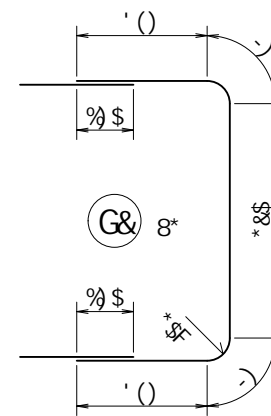
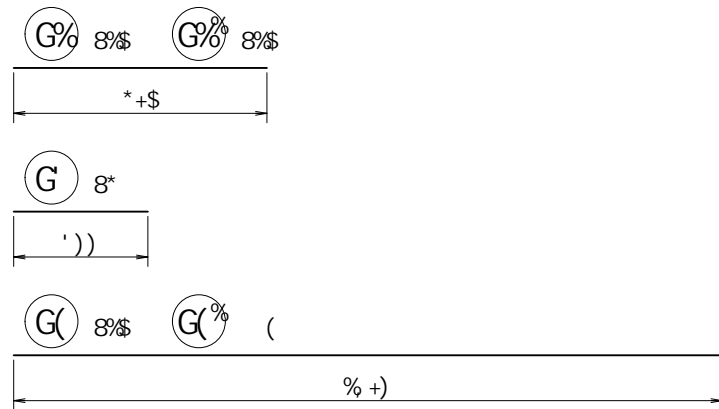
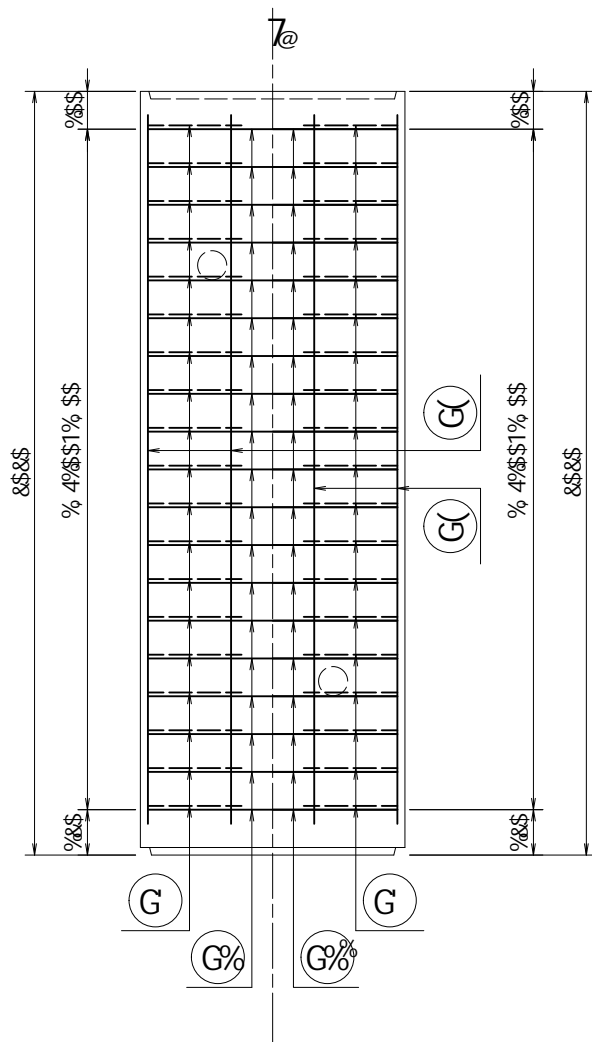
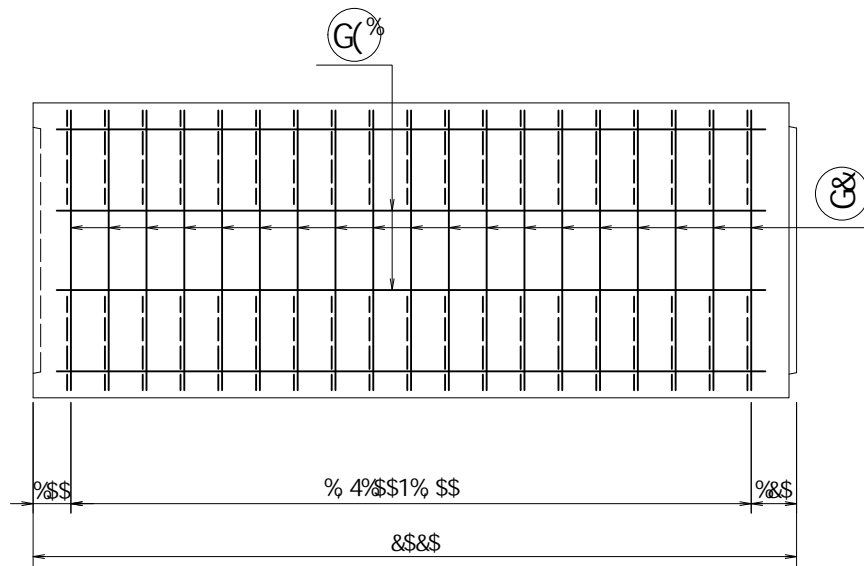
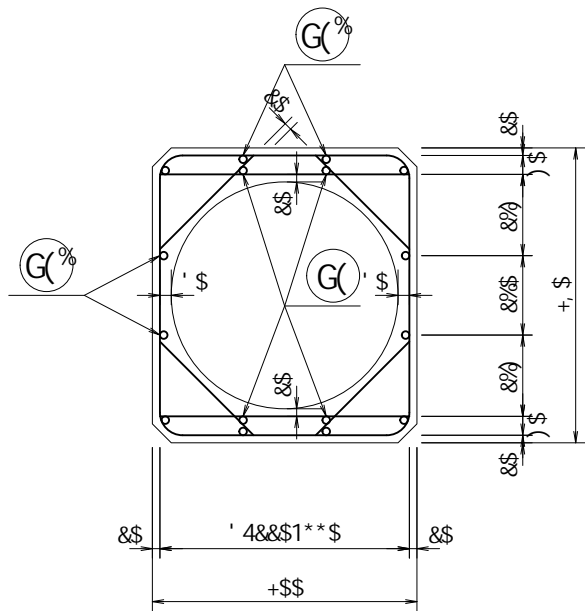

			a	┌	└	
G%	8%\$	%	'\$' * +\$	'\$') * \$	.. '+' %&-	—
G%	8%\$	%	'\$' * +\$	'\$') * \$	.. '+' %&-	—
G&	8*	'	'%) \$\$	'\$' &(-	'%' " %'	┌
G	8*	' +'	'\$' ! )	'\$' &(-	.. '*' +%	└
G(	8%\$	'	'%, +)	'\$') * \$	.. " (\$\$	—
G( %	(	'	'%, +)	'\$' \$, *	'%' (+	—
					'( )" \$(-	└
					.. '\$') %)	a'
					.. '%&' \$	└

		\$" \$\$\$a	(" (\$\$a
		—	H &)
		_B#a'	'&(")
		_B#a'	'%' "\$
		B#aa&	'(' )" \$
		B#aa&	'%&' \$
		B#aa&	'\$'" \$
	fIG&-)	└	B#aa&
		—	'\$'" )

		* \$\$! &\$\$\$	
		<&&' %\$" &-	% &\$
			<! %\$ \$* %&+,